

SIDE VIEW

FRONT VIEW

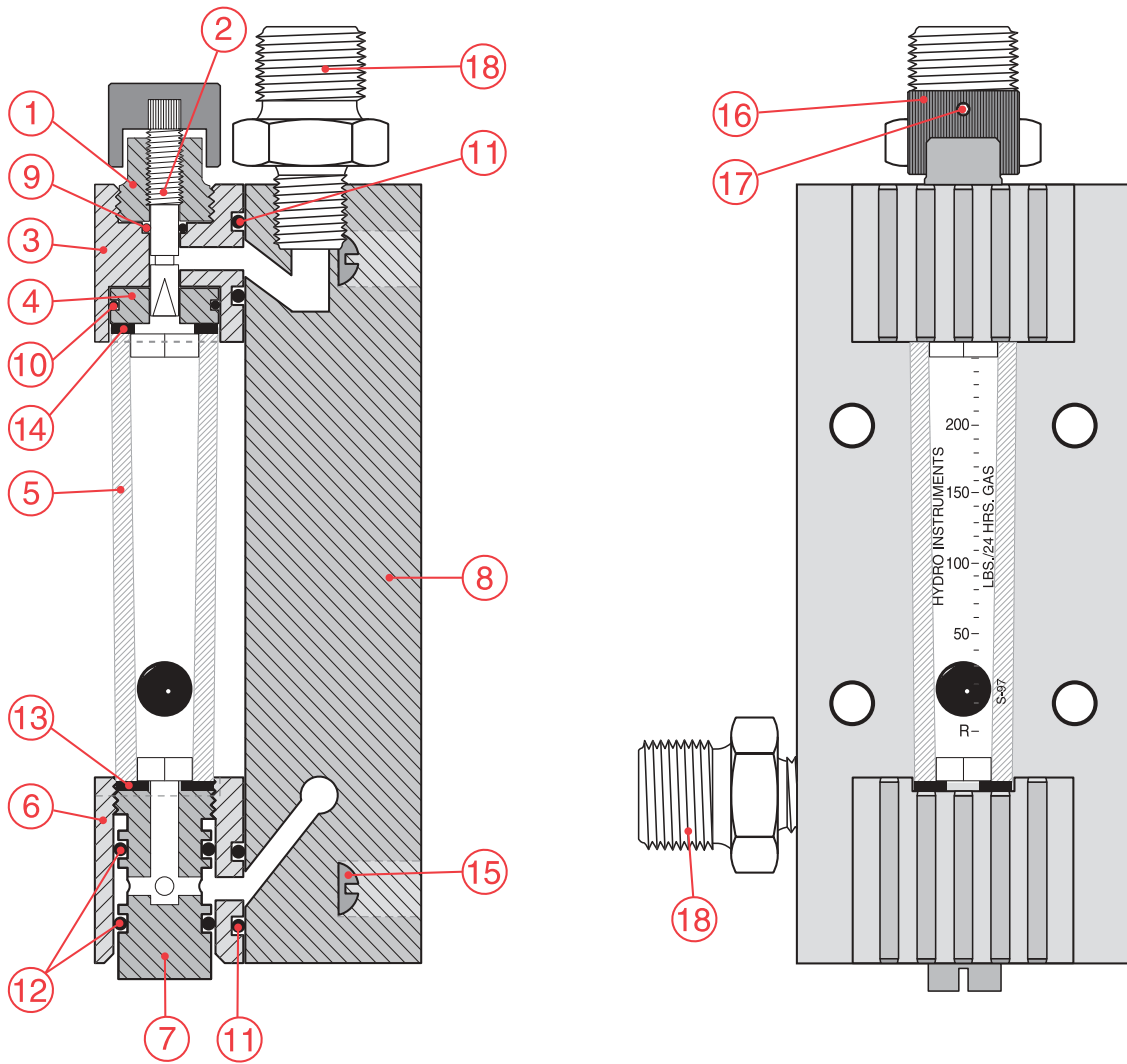

Item No.	Description	Quantity	Part No.
1	Valve Bonnet	1	VB-100C
2	Rate Valve	1	VP-203C
3	Top Meter Block	1	FM-200B
4	Rate Valve Seat (Teflon)	1	VT-204
5	Meter Tube	1	MTB-11-200
6	Bottom Meter Block	1	FM-203
7	Inlet Plug	1	FM-101A
8	Back Body	1	RM-1-200
9	O-Ring	1	3PS-106
10	O-Ring	1	3RS-016
11	O-Rings	2	3PS-110
12	O-Rings	2	3PS-112
13	Bottom Meter Gasket	1	MG-200B
14	Top Meter Gasket	1	MG-200T
15	Remote Meter Block Screws (stainless)	4	#10-24 x 1 1/4"
16	Rate Valve Knob	1	RV-100A
17	Rate Valve Knob Set Screw	1	#5-40 x 1/4"
18	1/2" Tubing x 1/4" NPT Tube Connector	2	F-106

hydro
INSTRUMENTS...
200 PPD REMOTE METER

Date: Nov. 1999
Scale: 80%
Dwg. No. RM-200